



# HOTEL SOLUTION

## INQUE Group

INQUE was born to provide Kitchen hardware solutions in Mumbai, India. Today, we are also providers of shutters and cabinetry. For us, providing the best customer service, customer experience and company culture is of utmost importance.

INQUE is a homegrown brand with its established, experienced and esteemed roots founded by a family that created ENOX.

A firm foundation for Pooja Hardware Pvt. Ltd. was laid down in the year 2007 with the brand ENOX with its product portfolio comprising Glass hardware, sliding solutions, door control, furniture fittings and kitchen hardware.

With time being grateful, our hard work helped us reach a commendable milestone of sales volume which progressively increased year on year.

In the year 2014, A Swedish multinational company named ASSA ABLOY acquired ENOX, with the branch of business that deals in locks and hardware. At that time, We were the market leader employing 220 passionate employees in our team. Since, the Kitchen Hardware business was not acquired from our product portfolio, we decided to continue our Kitchen Hardware under the INQUE brand with Pooja Hardware.

To take INQUE to a different height, we have started a new company named Inque Solution LLP. Inque Group of companies have acquired multiple brands, out of which AVEO Hardware India Pvt. Ltd. is one of its prized possessions.



Security is your concern; and ours is specialty. At RIOO, we believe your assets deserve better security that's easy to set up and use, and requires minimal attention and care while providing security and ease which cannot be compromised.

Established in 2015 as a Digital Door Lock brand, RIOO now has complete door hardware solutions along with home automation under its umbrella of products & services. A professional security smart solution provider, RIOO was born in Mumbai, India with its wings spread all across the country. With its distinct features in the digital lock systems, we have superior quality Digital Locks with 5-in-one features.

Our Keyless Solutions bring you the convenience to unlock your main door lock with Fingerprint, RFID Card, Mechanical Key, PIN Code or Mobile APP. Our Digital And Mechanical Security Locks (Mortise, Deadbolt, Rim, Cabinet) are continually pushing the limits of home security which works easily with doors.

Our locks are safe, strong and secure and have been tested to withstand adverse conditions. Not only are they technologically advanced but also have a high style quotient. With its sleek and contemporary design, they can aesthetically elevate your spaces. Customised designs are available for commercial, multi-family and mixed-use applications. RIOO products offer quality and value together while continuing the tradition of excellence every day. Today, countless people trust us and we believe it's just the beginning.

### VISION

To upgrade the community by evolving from the traditional mechanical locks to digital and affordable Door Lock Solutions.

### MISSION

To present an excellent digital & mechanical door solution hardware range with latest technologies and commendable service to our valued customers globally.



Mrs. BHAVNA SHAH  
CHAIRPERSON



Mr. DIVYESH SHAH  
MANAGING DIRECTOR



Mrs. RUPA SHAH  
CEO



CONTENT



Smart Hotel Lock  
**Page 004**



Elevator Controller  
**Page 013**



Bluetooth Hotel Lock System  
**Page 014**



Digital Safe  
**Page 016**

## HOTEL MANAGEMENT SYSTEM

compatible with most PMS (Fidelio, Opera, Prestige, etc)

Secure MSSQL enables multiple database access and stable information transmission.

Unique customer code for each hotel.

All-in-one-card solution: access to hotel entrance, sauna room, parking lot, fitness room,



**RDHL-2001**  
Smart Hotel Lock

MRP: ₹ 15,000/-

**FEATURES & SPECIFICATION**

Ways to Unlock	Card & Mechanical Key
Material	Stainless steel 304
Finish	Stainless steel brushed / gold
Application	Hotel & Apartment
Size	292.1mm x 78.01mm
Door Thickness	38mm - 45mm
Power supply	4 AA alkaline batteries
Life Cycle	Over 500000 cycles
Static current	< 20 uA
Dynamic current	<150 mA
Storage temperature	-25- + 58°C
Storage humidity	15-90% RH
Working temperature	-25- + 58°C
Working humidity	15-90% RH
Card reading distance	0-5cm
Reading & writing time	<0.25s
Applicable chip	Mifare 1 (13.56MHz)

**TECHNICAL DETAIL**

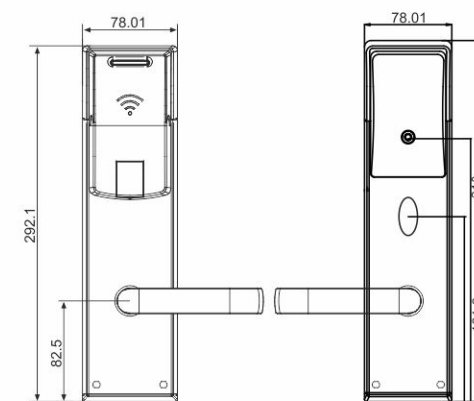

Lock Body Dimension

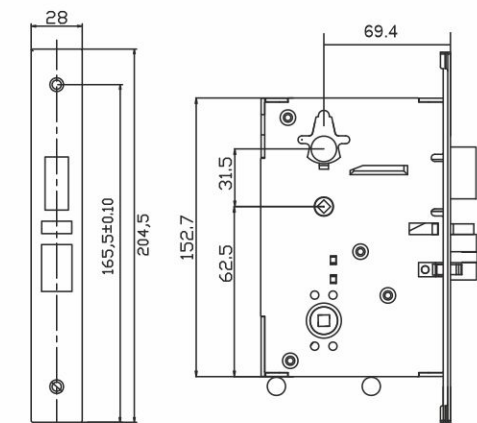

Mortise Body Dimension

**FUNCTION FEATURES**

- Card Unlocking
- Time Control Function
- Mechanical Key
- Low Power Alarm Function
- Integrated Manufacturing
- 8# Short Mortise
- 8# long Mortise
- Fireproofing
- Self-locking Protection



**PRIMO**  
SERIES

**RDHL-2002**  
Smart Hotel Lock

MRP: ₹ 20,000/-

**FEATURES & SPECIFICATION**

Ways to Unlock	Card & Mechanical Key
Material	Zinc alloy
Finish	Nanometer silver / gold plated
Application	Hotel & Apartment
Size	250mm x 70mm
Door Thickness	38mm - 45mm
Power supply	4 AA alkaline batteries
Life Cycle	Over 500000 cycles
Static current	< 20 uA
Dynamic current	<150 mA
Storage temperature	-25- + 58°C
Storage humidity	15-90% RH
Working temperature	-25- + 58°C
Working humidity	15-90% RH
Card reading distance	0-5cm
Reading & writing time	<0.25s
Applicable chip	Mifare 1 (13.56MHz)

**TECHNICAL DETAIL**

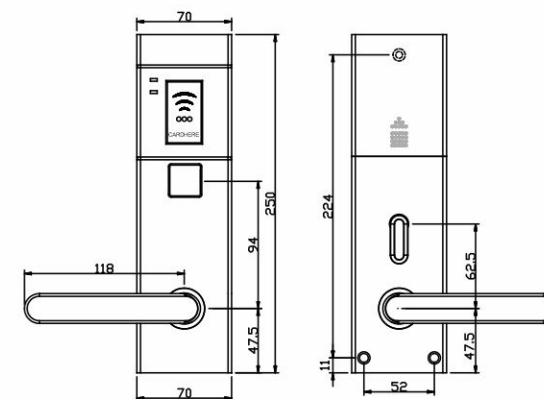

Lock Body Dimension

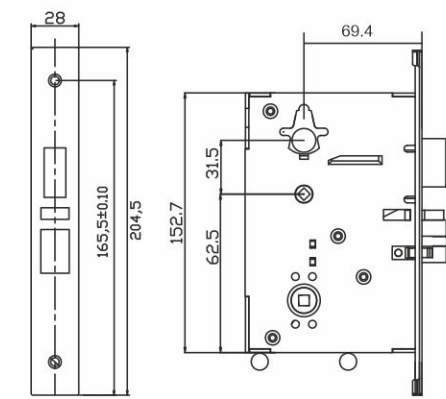

Mortise Body Dimension

**FUNCTION FEATURES**

- Card Unlocking
- Time Control Function
- Mechanical Key
- Low Power Alarm Function
- Integrated Manufacturing
- 8# Short Mortise
- 8# long Mortise
- Fireproofing
- Self-locking Protection



## RDHL-2003

Smart Hotel Lock

MRP: ₹ 20,000/-

### FEATURES & SPECIFICATION

Ways to Unlock	Card & Mechanical Key
Material	Aluminium alloy & acrylic
Finish	Black with silver / gold / coffee gold edge
Application	Hotel & Apartment
Size	300mm x 75mm
Door Thickness	38mm - 45mm
Power supply	4 AA alkaline batteries
Life Cycle	Over 500000 cycles
Static current	< 20 uA
Dynamic current	<150 mA
Storage temperature	-25- + 58°C
Storage humidity	15-90% RH
Working temperature	-25- + 58°C
Working humidity	15-90% RH
Card reading distance	0-5cm
Reading & writing time	<0.25s
Applicable chip	Mifare 1 (13.56MHz)

### TECHNICAL DETAIL

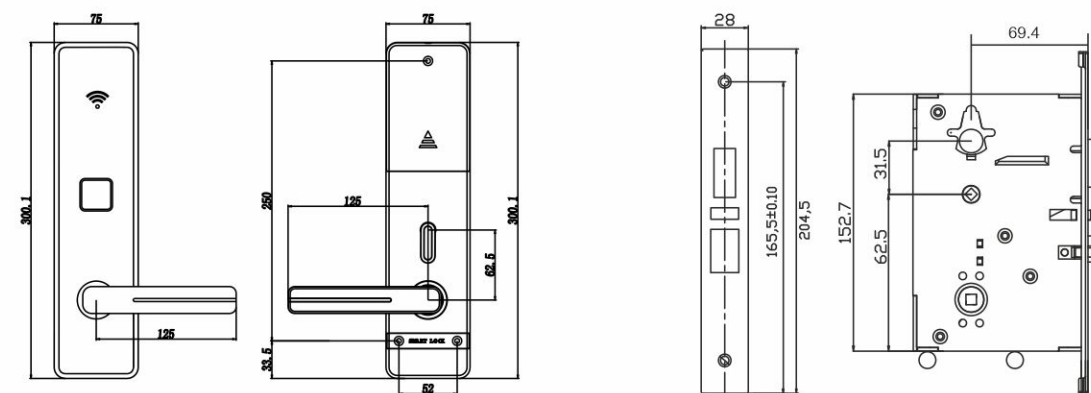

Lock Body Dimension

Mortise Body Dimension

### FUNCTION FEATURES





**RDHL-2011**  
Smart Hotel Lock

MRP: ₹ 9,500/-

**FEATURES & SPECIFICATION**

Ways to Unlock	Card & Mechanical Key
Material	Stainless steel 304
Finish	Stainless steel brushed / gold
Application	Hotel & Apartment
Size	242mm x 76.5mm
Door Thickness	35mm - 45mm
Power supply	4 AA alkaline batteries
Life Cycle	Over 150000 cycles
Static current	< 20 uA
Dynamic current	<150 mA
Storage temperature	-25- + 58°C
Storage humidity	15-90% RH
Working temperature	-25- + 58°C
Working humidity	15-90% RH
Card reading distance	0-5cm
Reading & writing time	<0.25s
Applicable chip	Temic (125KHz)

**TECHNICAL DETAIL**

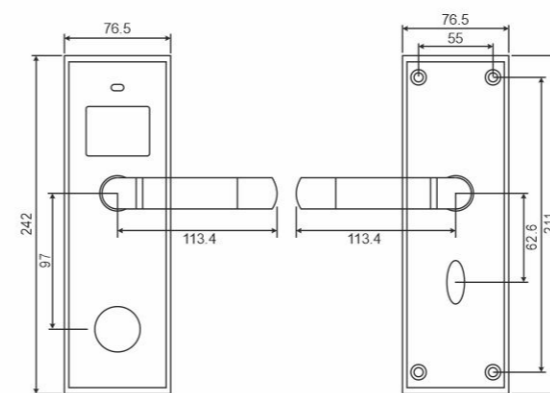

Lock Body Dimension

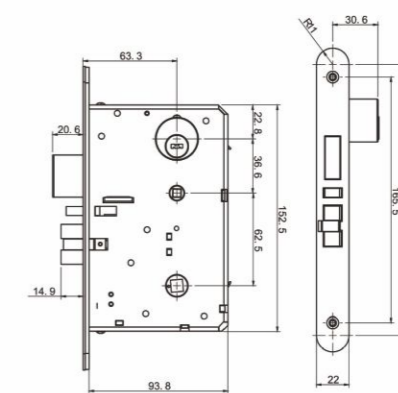

Mortise Body Dimension

**FUNCTION FEATURES**

- Card Unlocking
- Time Control Function
- Mechanical Key
- Low Power Alarm Function
- Integrated Manufacturing
- 8# Short Mortise
- 8# long Mortise
- Fireproofing
- Self-locking Protection

**PRIMO**  
SERIES



MRP: ₹ 45,000/-

**RDEC 2005**

CARD ENCODER



MRP: ₹ 99,999/-

**RDDC 2006**

WIRELESS DATA COLLECTOR



MRP: ₹ 3,100/-

**RDPC 2009**

ENERGY SAVING SWITCH

intelligent



MRP: ₹ 4,150/-

**RDPC 2010**

ENERGY SAVING SWITCH FOR UNIQUE ROOM



MRP: ₹ 20,000/-

**RDSC 2011**

SOFTWARE



MRP: ₹ 350/-

**RDMFC 2007**

MIFARE CARD



MRP: ₹ 4,500/-

**RDDCA 2008**

DATA CARD

**MEDIAN**  
ACCESSORIES



MRP: ₹ 15,285/-

**RDEC 2015**

ENCODER



MRP: ₹ 25,000/-

**RDDC 2016**

DATA COLLECTION MACHINE



MRP: ₹ 350/-

**RDTMC 2017**

TIMIC CARD



MRP: ₹ 1,850/-

**RDPSWTC 2019**

ENERGY SAVING SWITCH



MRP: ₹ 20,000/-

**RDSC 2021**

SOFTWARE CD



**ELEVATOR CONTROLLER**

- Card type : Mifare card;
- Card detecting distance 10-50mm;
- Sharing same management software with hotel lock;
- 3 control modes: uncontrolled mode, floor control, floor & time control
- Access control to certain floors can be cancelled during specific periods;
- Over 2000 entries record;
- Mini External reader is available for neat lift panel;
- Uncontrolled mode and access control mode can be interchanged by reading cards;

**TECHNICAL PARAMETERS**

Power supply	12VDC
Current	1000mA
Card type	Mifare card
Detecting distance	10-50mm
Input	N/A
Output	16 groups of normally-closed (NC) contacts 16 groups of normally-open (NO) contacts
Working environment	Working Temperature:-10°C~70°C Storage Temperature:-25°C~125°C Humidity:-5%~95%

**PRIMO**  
SERIES



**RDEC 3001**

**APO**

**ELEVATOR CONTROLLER**

- 2 delivery ways: automatic delivery and press-button delivery, 3 control modes: uncontrolled mode, floor control, floor & time control.

**MEDIAN**  
ACCESSORIES

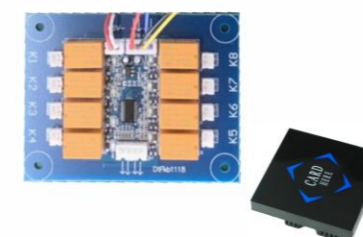

**RDEC 4001**

**APO**

**ELEVATOR CONTROLLER**

- Call Landing, Entering Elevator, Any Floor Optional, Without Pushing Button Reach The Floor Automatically, Optional PushingButton.



**RIOO BLUETOOTH HOTEL LOCK SYSTEM**

RIOO Bluetooth hotel lock solution is good choice for hotels/apartments/rental etc., It provides comprehensive functions such as **room property management, device management, room status management, authorization management, staff management, multi-function card management, reports, abnormal check-in alarm and PMS interface.** This system developed around rfid cards, Bluetooth and passwords. For example, has managing card function such as master card, building card, floor card. Support multi-terminal login (issue card from more than one computer). Support Windows / IOS / Android. **Provides a contactless check-in experience to guest.**

**Device control**

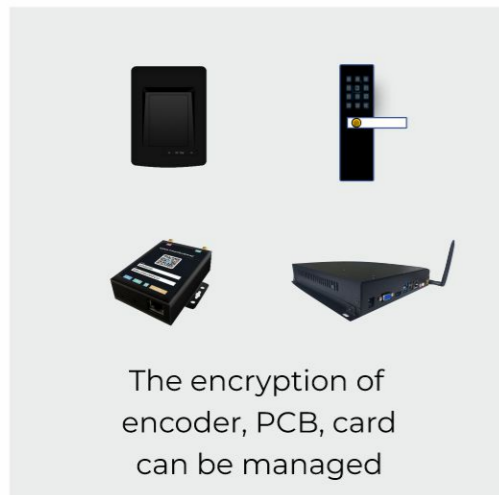

**Cloud+local Server framework**



**Issue card in multi-device**

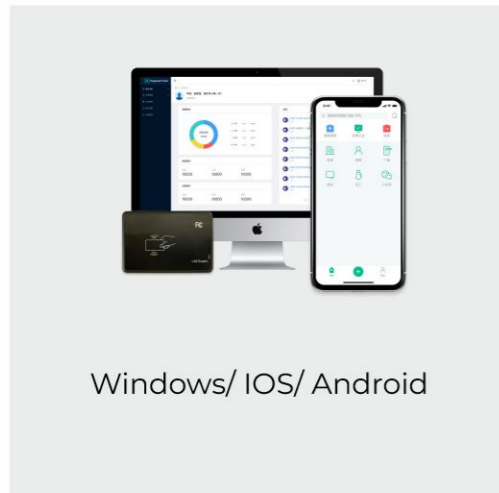

**Interface docking**

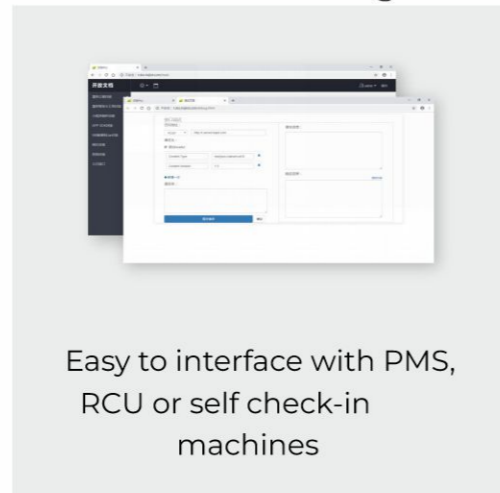

**“LOCAL + CLOUD” DUAL SERVER NETWORK HOTEL LOCK SYSTEM FRAMEWORK**

**System and PMS interface features**

1. Self-check-in, customer control system and third-party PMS only need one more network cable for docking
2. Support network issue CARD, IOS can issue too.
3. Expand APP unlocking. It doesn't need a third party to develop APP terminal, just send a request to the local area server network
4. Quickly connect with other project solution system

**Networked hotel lock system**

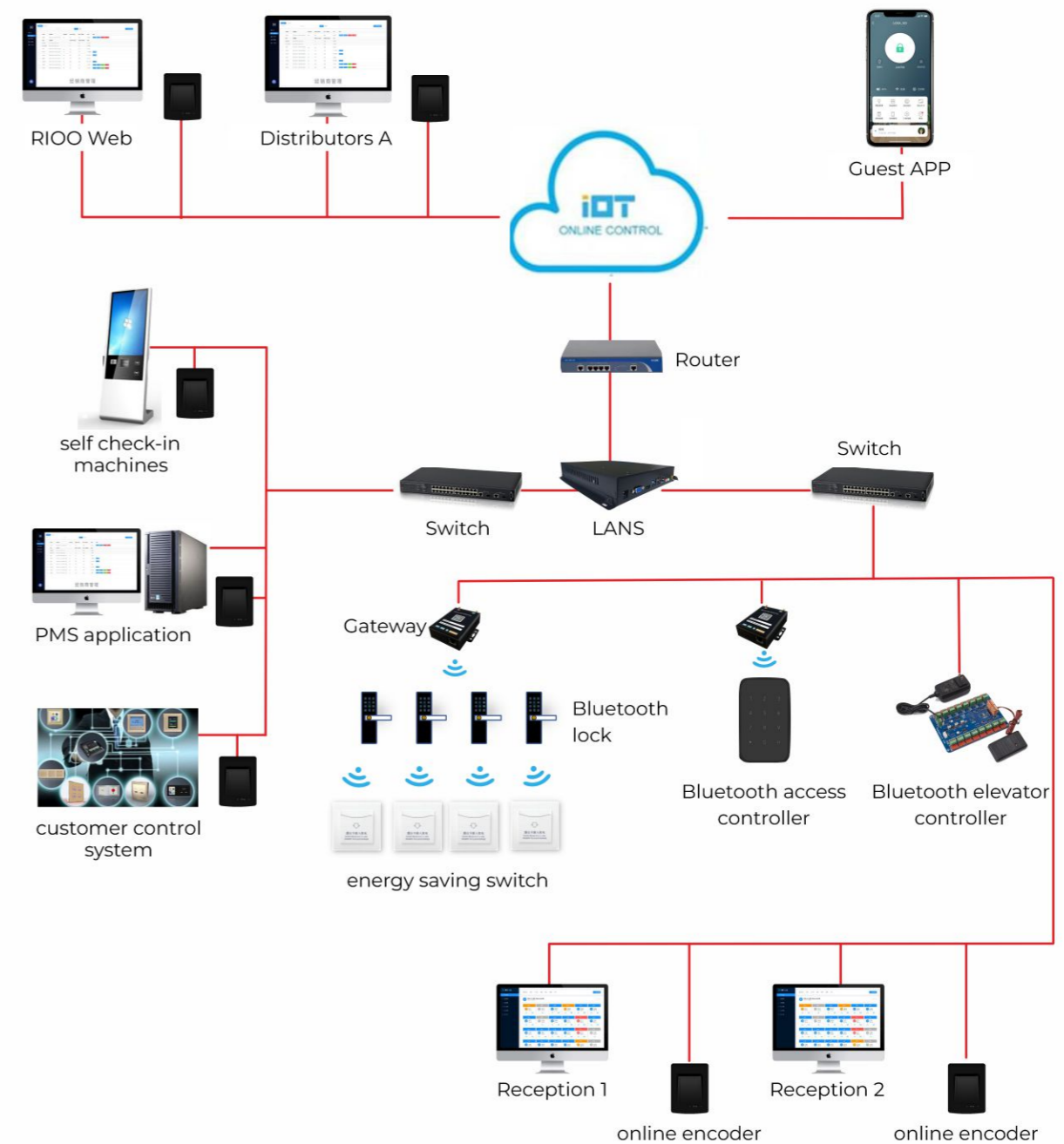



**STANDARD SAFE**

MRP: ₹ 8,999/-

**FEATURES**

- Open & Close with 3 - 8 digit code
- 20mm Locking bolts
- Override key for Emergency use
- Pre-drilled holes at the bottom and back
- Door : 4mm , Body : 1.5mm
- Run on 4 x 1.5V AA batteries (Included)
- Finish : Black

Code	Size (W x D x H)	Weight
RDES 5001	406 x 335 x 229	9.5kg



**GUEST SAFE**

MRP: ₹ 12,999/-

**FEATURES**

- Open & Close with 4-6 digit code
- Clear LCD display monitoring
- 100 Event audit trail recording
- 20mm Locking bolts
- Override key for Emergency use
- Suitable for floor or wall fixing (bolts included)
- Door : 5mm, Body : 1.5mm
- Run on 4 x 1.5V AA batteries (Included)
- Finish : Black

Code	Size (W x D x H)	Weight
RDES 5002	432 x 380 x 195	11.5kg



**RDESD 5002**

Wireless Data Collector for Guest Safe

**DIGITAL SAFE**





INQUE Group



**RIOO DIGITAL INDIA PRIVATE LIMITED**

C 8/9/10, Hind Saurashtra Industrial Estate, Andheri - Kurla Rd,  
Nr Mittal Ind. Estate, Marol Naka, Andheri (E), Mumbai-400059.

E: [customercare@riooin.in](mailto:customercare@riooin.in) | W: [www.riooin.in](http://www.riooin.in) | T: 1800 123 3320

Mumbai | Agra | Ahmedabad | Bengaluru | Bhubaneswar | Chandigarh | Chennai | Delhi NCR  
Guwahati | Hyderabad | Jaipur | Kolkata | Lucknow | Pune | Surat | Raipur | Rajkot | Varanasi

